

INSTALLATION INSTRUCTIONS

FOR

AIR CONDITIONING CAT D6M

WITH REMOTE CONDENSER



HAMMOND AIR CONDITIONING LTD
INGERSOLL, ONT, CANADA
1-800-267-2665

EVAPORATOR COIL: The evaporator coil mounts in front of the heater coil directly ahead of the cab windshield.

1. To access, remove the filter intake cover and the air filter coil and A/C hose knockouts. Loosen the two bolts that hold the heater coil in.
2. Insert the evaporator core into the area in front of the heater coil. Line the slots on the mounting flanges on the evaporator coil up with the two bolts that held the heater coil in place.
3. Tighten down the heater bolts to clamp the evaporator into position.
4. Seal any air gaps around the top or sides of the coil.
5. Leave covers off until the thermostat has been installed and the system has been tested for leaks.



Evaporator in place alongside heater coil.



Top of evaporator assembly in heater box.



Evaporator assembly showing hoses.



Evaporator cover in place with thermostat.

THERMOSTAT: The thermostat mounts in the factory position on the front dashboard.

1. Open the control panel in front of the operator's position to access the wiring and set-up locations for the thermostat.
2. Locate the factory position for the thermostat (see photograph) and cut out the covering over the mounting hole. Make sure the thermostat has the backing nut in place before installing. Insert the thermostat into the hole. Tighten down the securing nut and install "Temp" knob.
3. Run thermostat probe out of the cab (through the factory knockout) into the evaporator coil area. Insert the probe into the evaporator coil about 6".



Thermostat location (one possible position)



Thermostat location (possible – depends upon instrument locations)

Another option for the thermostat is to use a pre-set style. This will allow the thermostat to be hidden behind the instrument panel but will not allow the operator to adjust for personal comfort. **Please advise thermostat style when ordering system.**

COMPRESSOR: The compressor is mounted on the boss surrounding the heater line tap on the engine.

1. Bolt the compressor mount onto the flat boss plate using the pre-tapped holes in the late using the hardware provided in the kit.
2. Install the idler pulley assembly with correct spacer arrangement onto the front of the engine the location shown in the picture.
3. Place the compressor on the mount tightener ears as shown in the pictures.
4. Route the belt around the compressor, crankshaft pulley and the idler pulley. Tighten using the adjuster ears built into the compressor mount.

****NOTE**** Ensure the oil fill port on the compressor is oriented 'UP'



Compressor mount location.

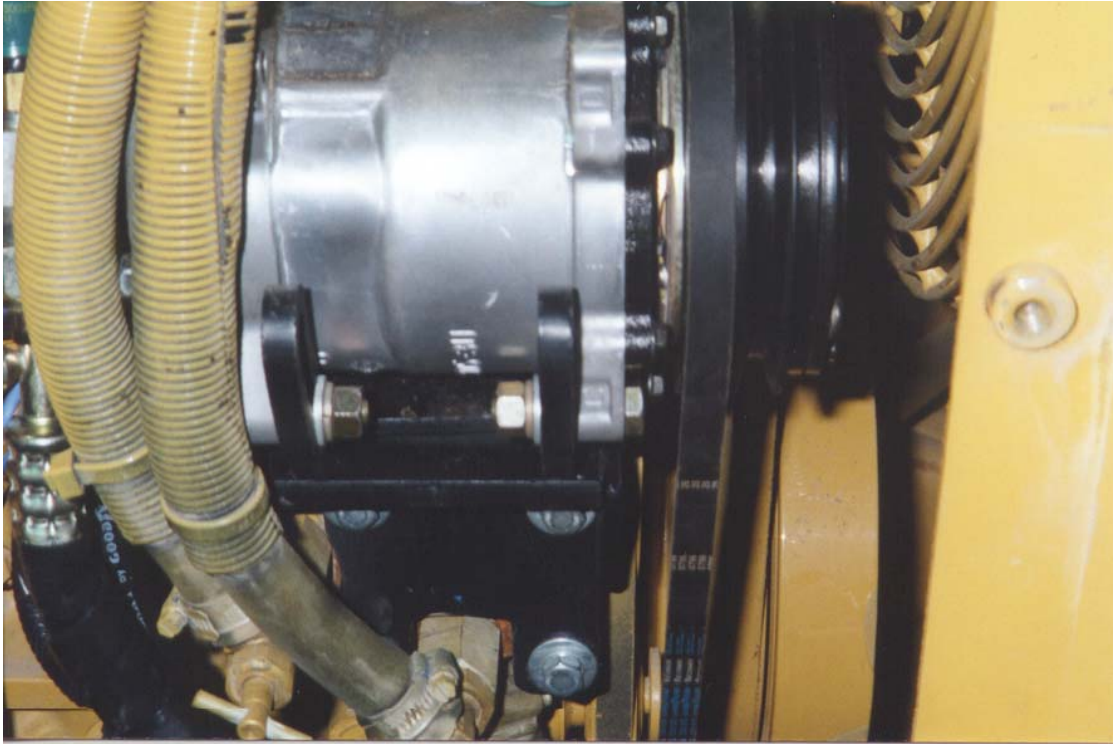

Compressor arrangement in place.



Compressor mount and drive with idler pulley.

CONDENSER ASSEMBLY: The severe duty condenser is mounted off the back of the cab as shown in the pictures. The mounting frame uses some of the same bolt locations as the factory arrangement would.

1. Remove the condenser frame from the assembly and make sure there are two mounting frame components. One will be a 'Z' type bracket of 2" angle iron and the other will be a long 'U' shaped bracket.
2. The bottom bracket is the 'U' shaped bracket and bolts onto the upper mounting bosses on the ROPS uprights. The 'Z' brackets are centered on the roof and bolted down to the roof and to the lower bracket. The roof holes must be marked and drilled. When bolting the 'Z' brackets down on the roof it is important to seal the bolt holes with silicon, or another sealer, to prevent water leaking into the cab.
3. Bolt the condenser arrangement to the mounting brackets with the hardware provided and ensure that the arrangement is secure.



Left side of condenser assembly.(D5M SHOWN)



Right side of condenser assembly.(D5M SHOWN)

ELECTRICAL: The wiring set-up used in this system is designed to be very straightforward to install and understand.

1. The thermostat is mounted in, or behind, the main control panel as described above and draws power from the relay.
2. The blower switch will have one position that is live when the switch is in any of the 'Air Conditioning' blower positions. This will provide the control power to the relay.
3. Cut the yellow wire coming off this post into the wiring bundle and connect to the wire coming from the control side of the relay (14ga red).
4. Run the black 14 gauge clutch wire (with loom) out into the heater box along with the thermostat probe. The probe is inserted into the coil through the hole in the cover plate and at least 6" into the coil.
5. The clutch wire runs out of the heater box with the suction hose and runs up to the compressor where the pressure switches are located.
6. Connect in series through the switches (order is not important) and connect to the compressor lead.
7. Main power is drawn from a battery live location in the main electrical panel at the rear of the cab. Connect the power source to a 30A breaker mounted at the panel with a 10ga wire (should be no more than 24").
8. From the breaker connect to a relay mounted on the side of the panel (see picture) with a 10ga wire to the #30 post.
9. There will be two 14ga wires from the front controls in the cab. The red wire runs from the clutch post on the blower switch and the black wire runs from the thermostat. Connect the red wire to the #85 post on the relay and then ground the #86 post to the frame.
10. The black 14ga thermostat wire and the red 10ga condenser power wire to the #87 post on the relay. Run the 10ga power wire up with the hoses to the condenser.

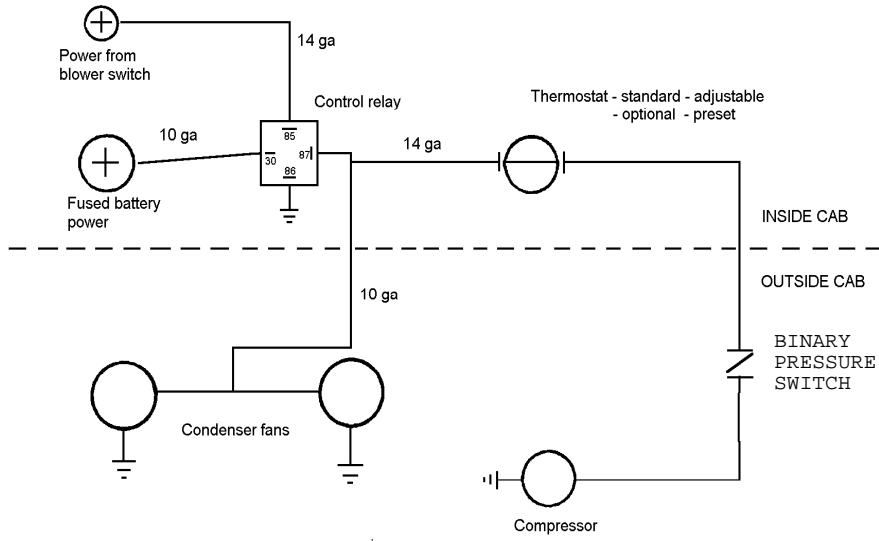

Wiring diagram for D5M with Heavy Duty Condenser assembly.



HOSE RUNS: All the hose fittings have been pre-crimped at one end at least and tested for leaks.

5/16" hose drier to expansion valve:

Connect the 90o fitting on the hose to the 'OUTLET' fitting on the drier. From here, route the hose down the left hand ROPS post and into the electrical compartment at the back of the cab. From here route under the cab and forward to the back of the engine. Route the hose across the back of the engine compartment and to the right side beneath the evaporator area. The cap plug will have to be slit as shown below to get the hoses through to the evaporator. Cut the hose to length and crimp on the straight fitting supplied in the kit. Connect the straight fitting up to the expansion valve.

13/32" hose compressor to condenser:

Connect the 90o fitting with the 134a charging port up to the rotolock fitting on the discharge side of the compressor. Route the hose down to the frame and then back along the side of the engine to where the 5/16" hose comes out from under the cab. From here route the hose to the condenser with the 5/16" hose and secure the two hoses together and to the tie down points as necessary. Cut the hose to length and crimp on the 90o fitting on the end. Connect the 90o fitting to the condenser as shown in the condenser mounting pictures.

1/2" hose compressor to evaporator:

Connect the 90o fitting with the 134a charging port up to the rotolock fitting on the suction side of the compressor. Route the hose down to the frame (with the 13/32" hose) and back along with the 5/16" hose to the evaporator assembly. Route the hose through the cap and connect to the outlet side of the evaporator.



Hoses into evaporator box with clutch wire in background.

IMPORTANT: Make sure "O" rings are used on all fittings. Use refrigeration oil on all "O" rings to achieve a proper seal.

Refrigerant Flow Pattern in a Standard Air Conditioning System

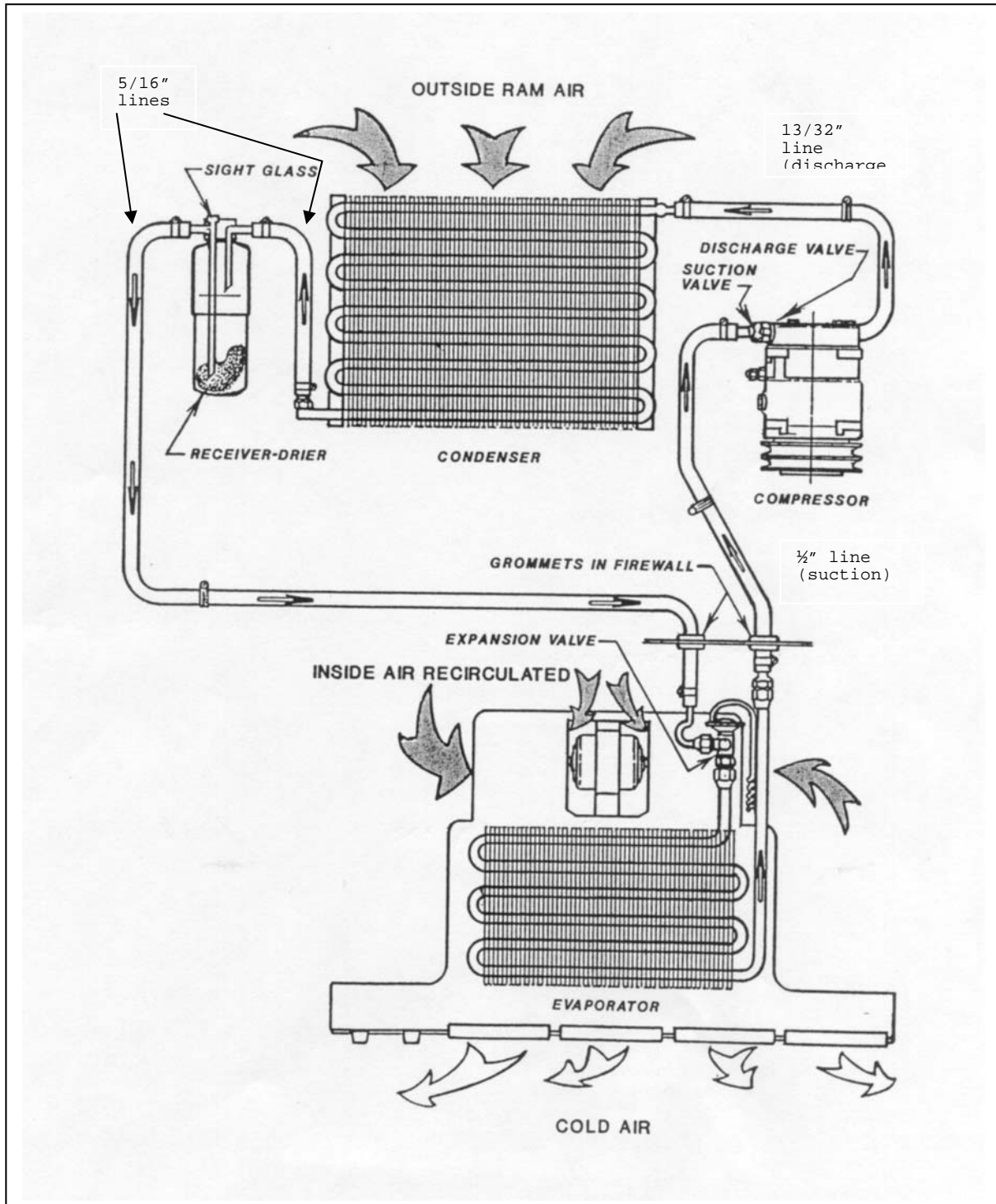

Thermostat Setting Procedures

- 1) Thermostat types
 - a) preset
 - b) adjustable
 - a) A preset thermostat is adjusted to its specific cut in and cut out temperatures when manufactured and does not have a rotary adjustment for the operator.
 - b) An adjustable or rotary thermostat has been manufactured to a predetermined cut in and cut out temperatures, but it is also operator adjustable to achieve the desired comfort level.

Both types of thermostats can have their factory settings adjusted by turning the setting screws on the body of the thermostat. One body type has the setting screws mounted externally and labeled for direction of rotation. The other body type requires the removal of the plastic end plate to expose the set screw.

- 2) Thermostat probe location: The location of the thermostat probe in an evaporator coil can be very important to achieve the maximum cooling potential of the coil while also preventing coil freeze-up. There is no set location for the thermostat probe to be put that will be optimum for all systems, but several rules of thumb may be followed:
 - a) Insert the probe in the coldest area of the evaporator coil.
 - b) Insert the probe from the top of the coil down, if possible.
 - c) Make sure that at least the last 3” of the thermostat probe are in the coil.

To find the most likely area where the coil is the coldest, consider these factors:

- 1) Direction of air flow through the coil.
 - 2) The coil area likely to have the lowest air flow.
 - 3) The inlet locations of the refrigerant into the coil.
 - 4) The inlet of the hotter outside air into the coil area.
-
- 1) Usually the coldest side of the evaporator coil will be the air outlet side. Often the thermostat probe can be inserted between the last and second last row of tubes.
 - 2) The lower air flow area of the evaporator coil in most systems tends to be near either end of the coil. These areas will be colder
 - 3) The area of the coil that the refrigerant inlet tube(s) occupy should be the coldest part of the coil.
 - 4) If the system is equipped with an outside air intake, where and how that air is brought into the evaporator area can have a large effect on the coil temperature. If all the outside air is piped into the evaporator in one area, that area will be considerably warmer in hot weather.

By looking at all these different factors, the area of an evaporator coil most likely to be the coldest can be determined.

Once the probe is inserted, the A/C system needs to be tested. Run the system to ensure that the thermostat is cycling the compressor off at the appropriate temperature. A core temperature ranging between 25° and 30° F should cause the thermostat to cycle off. The air temperature at the vent outlet closest to the evaporator coil should be between 38° F and 45° F when the compressor cycles off.

If the thermostat doesn't cycle off after a reasonable cool down period, and the air outlet temperature has dropped below 40° F, the cut in and cut out settings should be adjusted until the compressor is cycling on and off regularly. Let the system run for a decent time period (at least 15 min) and then check the evaporator coil for any signs of freezing.

Aeroquip E-Z Clip Assembly Instructions

Step 1. Cut the hose to proper length with an appropriate cutting tool. Aeroquip's hand held hose cutter has been specially designed for cutting all non-wire reinforced hose, such as GH-134 Multi-Refrigerant hose. Be sure the cut is made square to the hose length.

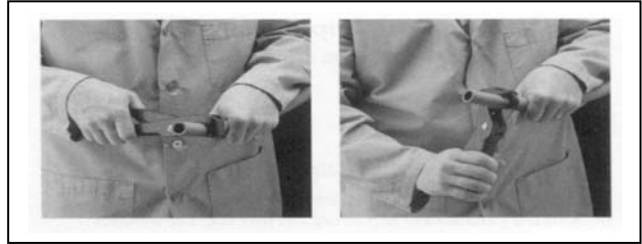

Step 2. Install two proper-sized clips onto the cut end of the hose. Orientation of the clips does not affect the performance of the connection. However, for ease of assembly, both clips should have the same orientation. NOTE: Failure to slide the clips over the hose at this time will require the clips to be stretched over the hose or fitting later. This may permanently damage the clip.

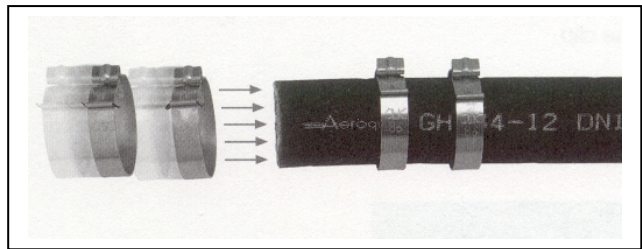

Step 3. Lubricate the nipple with a generous amount of the refrigeration or A/C system's compressor lubricating oil. This MUST be done to lower the force of nipple insertion.

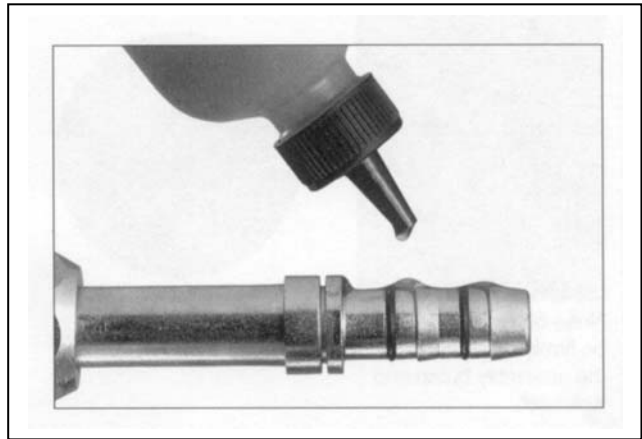

Step 4. Insert the nipple into the hose. To ensure that the nipple is fully inserted, check the gap between the cut end of the hose and the shoulder on the nipple. Care should be taken to avoid kinking or other damage to the hose during nipple insertion. NOTE: Be sure to wipe excess oil from the nipple and hose.



Step 5. Snap the cage into the groove on the nipple. The arms should extend over the hose length. When the cage has been correctly installed in the cage groove, the cage will be able to rotate in the groove. This step **MUST** be performed to ensure:

1. The clips will be located over the O-rings on the nipple.
2. The connection will be compatible with the connection's pressure rating.

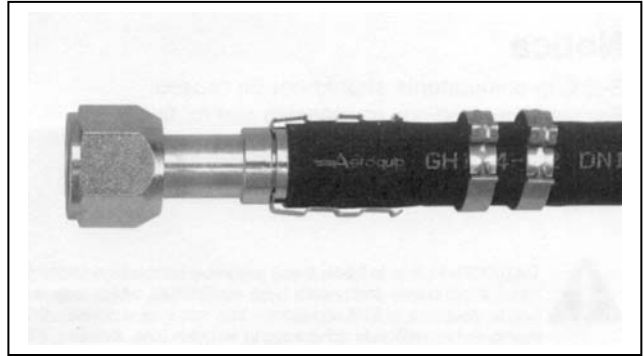

Step 6. Slide the clips over the cage arms and into the channels on each arm.

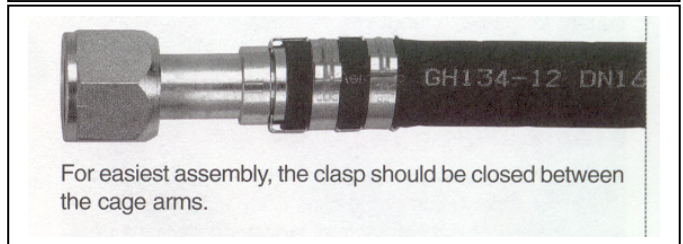
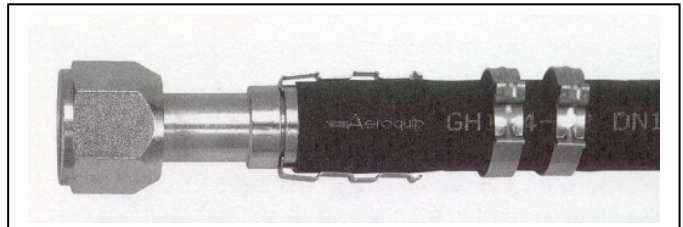

Step 7. Use the pliers to close the clips. The pliers should be positioned squarely on the clip connection points and should remain square during the closing of the clip.

NOTICE: E-Z Clip components should not be reused.

